



HDMI® Port Processor

Featuring 3D over HDMI, HDMI Ethernet Channel, Audio Return Channel, Content Type Bits, plus Innovative InstaPort™ Technology

The SiI9389 is a second generation port processor offering comprehensive HDMI Specification Version 1.4 features for DTVs and AVRs. The SiI9389 transforms the viewing experience with 3D cinema and games while simplifying home connectivity by eliminating the need for separate Ethernet or S/PDIF cables and connectors. Silicon Image port processors feature InstaPort™ technology for fast switching times between sources.

HDTVs are evolving by adding 3D video and IP content and services. Bringing 3D video to the home enhances the consumer home theater experience while HDMI Ethernet Channel enables new applications to run over TCP/IP, UPnP, and LiquidHD™ protocols. Both combine to create a new personal entertainment experience.

The Silicon Image family of port processors enable OEMs to differentiate with innovative features offering consumers real value. The SiI9389 port processor outputs to the HDMI interface, requiring no change to the system architecture while providing the flexibility to introduce features as the market demands.

The SiI9389 switches between five HDMI 1.4 input ports. All ports support 3D Video and Content Type bits, which specify the video type in the HDMI data stream. HDMI Ethernet

Channel - a high-speed, 100 Mb/sec full-duplex networking data channel and S/PDIF Audio Return Channel are supported on any one port. All HDMI 1.4 signals, including audio, video, EDID, HDCP and CEC are fully supported.

The SiI9389 includes Silicon Image's InstaPort technology which can dramatically reduce switching time between different sources to as low as one second. It also supports the Silicon Image MHL™ (Mobile High-definition Link) technology, a low-power, low-pin-count solution that enables mobile phones, digital cameras, portable media players and other mobile devices to connect directly to HDTVs. MHL formats are auto-detected on up to two ports.

The SiI9389 port processor is complemented by the SiI9334 HDMI transmitter for source devices with the same rich HDMI 1.4 feature set.

SiI9389

Applications

- LCD, plasma, OLED and front and rear projection DTV

Key Features

- Five HDMI input ports
- 3D over HDMI
- HDMI Ethernet Channel
- Audio Return Channel with S/PDIF input
- Content Type Bits
- InstaPort™ switching technology
- MHL™ technology
- Built-in HDCP decryption engines
- TMDs Core @225MHz

HDMI®
HIGH-DEFINITION MULTIMEDIA INTERFACE

instaport™

SiI9389 System Diagram

Up to 5 HDMI® or 2 MHL™ Sources

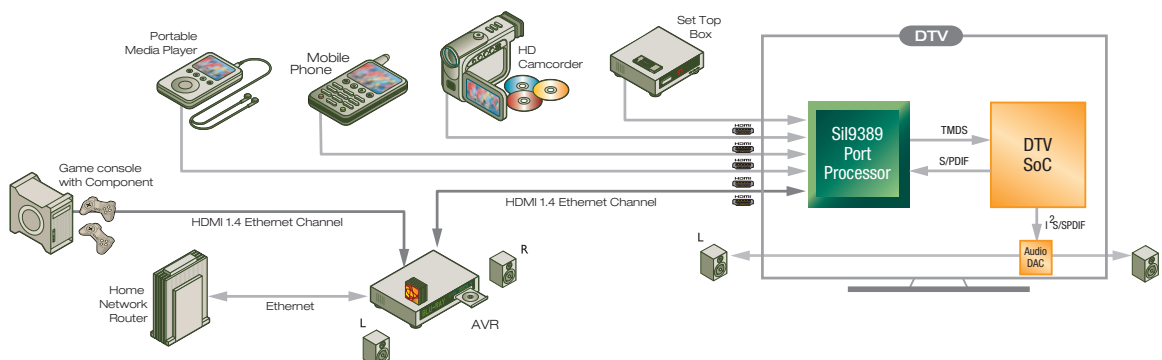

Sil9389 Features

Sil9389 Starter Kit (CP9389HDMI)

Contents include:

Hardware

- Sil9334 source board
- Sil9389 sink board
- HDMI ethernet cable

Software

- Simon receiver software tool

Documentation

- User's guide
- Schematics
- Bill of materials (BOM)

Industry-Standard Compliance

- HDMI 1.4
- DVI 1.0
- EIA/CEA-861E
- HDCP 1.1

HDMI/MHL Inputs

- Five HDMI 1.4 input ports:
 - 3D Video formats (1080i @ 50/59.94/60Hz, 1080p @ 23.98/24Hz, 720p @ 50/ 59.94 /60Hz) on all ports
 - HDMI Ethernet Channel/Audio Return Channel on any one port
 - Content Type Bits on all ports
- One unencrypted HDMI output
- 36 bit color depth resolutions up to 1080p @ 60Hz or 720p/1080i @ 120Hz
- InstaPort™ fast HDMI port switching
- Up to two MHL auto-sensing ports with 24 bit color depth and input resolutions up to 1080p @ 30Hz or 720/1080i @ 60Hz
- Shared EDID NVRAM for HDMI andVGA ports

- DDC/EDID for VGA
- Integrated CEC Consumer Electronics Control

System Operation

- Register-programmable via slave I2C interface

Content Protection

- Integrated HDCP cipher engine
- Built-in HDCP BIST (self-test)
- Pre-programmed HDCP keys

Power Management

- Low standby power mode with auxiliary power mode for CEC and EDID support
- Network “On”, TV “Standby” power mode enables networking functionality while the TV display is not powered
- < 2.0W power consumption

Package

- 100-pin, 14mm X 14mm, 0.5mm pitch QFP



Sil9389 Block Diagram

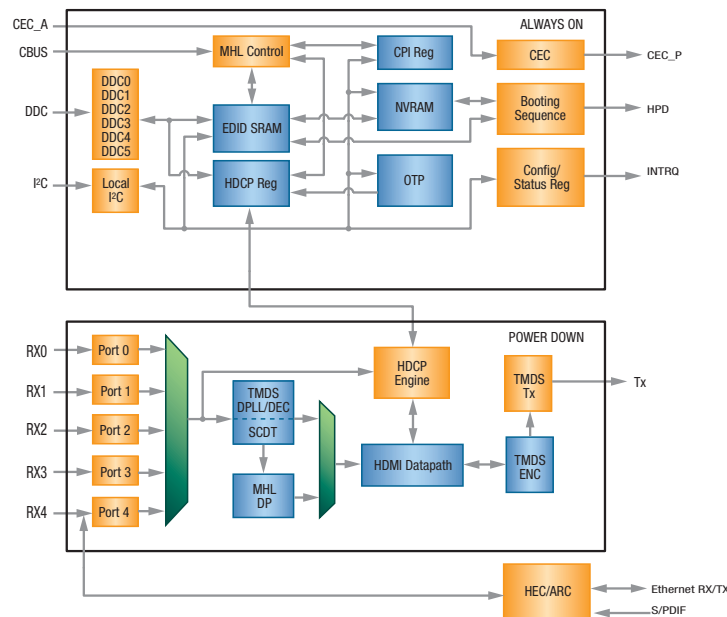

Silicon Image, Inc.

1060 E. Arques Avenue
Sunnyvale, CA 94085

T 408.616.4000

F 408.830.9530

www.siliconimage.com

Simply Stored. Connected. Beautiful.

Copyright © 2009 Silicon Image, Inc. All rights reserved. Silicon Image, the Silicon Image logo, Si9389, Si9334, MHL, InstaPort, the InstaPort logo, MHL, and LiquidHD are trademarks or registered trademarks of Silicon Image, Inc. in the United States and/or other countries. HDMI, the HDMI logo, High-Definition Multimedia Interface, are trademarks or registered trademarks in the United States and/or other countries and are used under license from HDMI Licensing, LLC. All other trademarks are the property of their respective owner in the United States and/or other countries. Product specifications are subject to change without notice.